

Bulletin 2801-91

# Model 2801

## Bonded Strain Gage Pressure Transmitter

*High Performance,  
2-Wire Industrial Pressure Transmitter*



### Features:

- 4-20 mA standard 2-wire output.
- Operates from unregulated power source.
- Entirely welded stainless steel construction.
- Simple installation -no brackets required.
- Designed for hazardous location service.
- Unaffected by power supply reversal.

### Options:

- Bleed port 1/16-27 NPT female.
- Pressure fitting per AE F2S0-C<sup>®</sup> with 9/16-18 NF internal thread.
- Special electrical connections.

### Pressure Ranges:

PSIA	PSIG	BAR
0-50	0-50	0-3.45
0-100	0-100	0-6.89
0-200	0-200	0-13.8
0-500	0-500	0-34.5
0-1000	0-1000	0-68.9
0-2000	0-2000	0-138
0-5000	0-5000	0-345
0-10,000	0-10,000	0-689
0-20,000	0-20,000	0-1378

(PSIG has 14.7 PSIA Ref.)

# Model 2801

## Bonded Strain Gage Pressure Transducer

### Specifications:

Materials	Case and electrical fitting -304L and 316L stainless steel. Pressure fitting and pressure cavity -17-4PH stainless steel. Options available.
Full Scale Output	4-20 mAdc corresponding to zero to FS pressure.
Span	16.00 ±0.16 mAdc at 24 Vdc.
Zero Balance	4.00 ±0.16 mAdc at 24 Vdc.
Accuracy	Within ±0.25% of span measured by best fit straight line method to include combined effects of linearity, hysteresis and repeatability at +70°F (+21°C). Within ±0.50% of span for 15 PSI units.
Resolution	Infinite.
Proof Pressure Rating	0-50 PSI ranges: 5.0 times range. 0-100 thru 0-20k PSI ranges: 2.0 times range. Application of proof pressure will not cause any change in performance characteristics.
Burst Pressure Rating	0-50 PSI ranges: 10 times range. 0-100 thru 0-20k PSI ranges: 4 times range.
Compensated Temperature Range	-30°F to +170°F (-34°C to +77°C).
Operating Temperature Range	-65°F to +200°F (-54°C to +93°C).
Thermal Sensitivity Shift	Less than ±0.010% of span per °F over compensated temperature range (±0.018% per °C).
Thermal Zero Shift	Less than ±0.010% of span per °F over compensated temperature range (±0.018% per °C).
Shock	30 G's for 11 milliseconds will not cause change in transmitter performance characteristics.

### Specifications:

Excitation	15-40 Vdc unregulated at transmitter with performance unaffected by power supply reversal. Any loop resistance is acceptable provided excitation at transmitter is between 15-40 Vdc. Span and zero sensitivity to excitation at the transmitter is less than 0.05% of span per volt. Calibrated at 24 Vdc
Insulation Resistance	1000 megohms at 50 Vdc between both leads in parallel and case at +70°F (+21°C).
Pressure Connection	1/2-14 NPT internal. Maximum recommended applied pressure with this fitting is 25,000 PSI/. For applications where higher pressures are expected, the AE F250-C® cone is recommended and is available as an option.
Mounting	By pressure fitting. Unit is not position sensitive.
Bleed Port	1/16-27 NPT available as option.
Electrical Connection	1/2-14 NPT internal for rigid conduit with two 3 foot leads, 16 AWG.
Weight	Approximately 24 ounces (672 g).

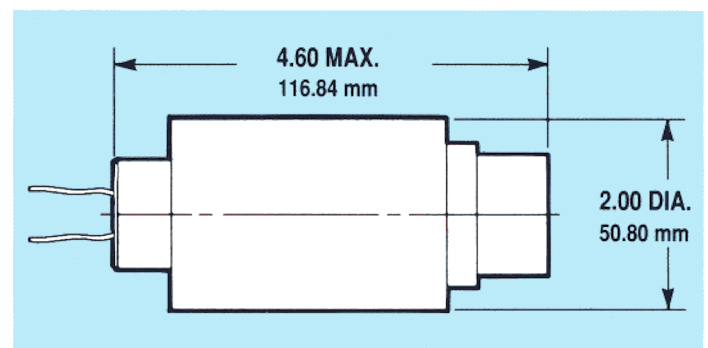

455 Bryant Street  
North Tonawanda, New York 14120 USA  
Phone 1.800.333.5300 (U.S.) or 716.694.4000 (outside U.S.)  
Fax 716.694.1450  
Email [sales@taberindustries.com](mailto:sales@taberindustries.com)  
Visit us at [www.taberindustries.com](http://www.taberindustries.com)

TK05/02